

SUBJECT: FREEDOM SERIES LTR STANDARD DECK WET ENGINE BLOCK

FPE-2025-156
 October, 2025
 Page 1 of 2

OVERVIEW AND SPECIFICATIONS

P/N: FPE-LTR-SD10X

CONTENTS:

Item #	Description	QTY
1	LTR wet deck engine block (not pictured)	1
2	LTR rear cover	1
3	LTR cam thrust plate	1
4	Durabond cam bearings	5
5	Transmission dowel pin	2
6	Rear oil seal housing o-ring (GM 19166180)	1
7	Thrust plate o-ring (GM 19166178)	1
8	Rear cover o-ring	1
9	Oil galley bar bell	1
10	Rear cover bolts	12
11	Cam thrust plate bolts	6
12	Oil galley freeze plug	1
13	Steel oil galley plug	1
14	Brass coolant plug	1
15	16mm water plugs	1
16	Rear main seal	1

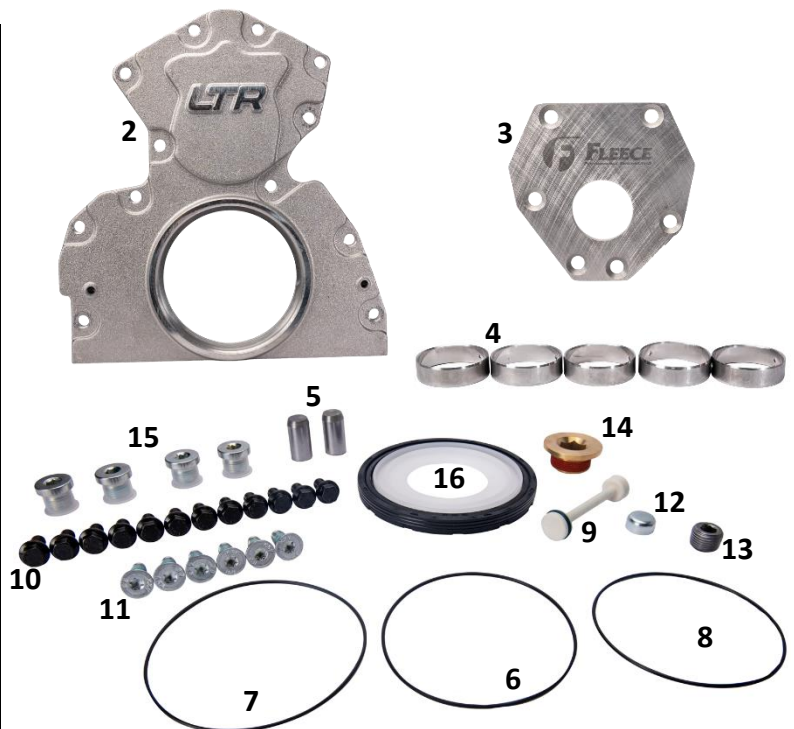

BUILDER NOTES:

- The LSR block is semi-machined and requires final machining to the builder's final specifications for the application. Required machining includes:

- Final deck surface (0.011" additional provided on the deck surface)
- Final cylinder hone
- Final OD on the crankshaft mains (0.003" additional provided for the final hone)

- The camshaft and lifter bores are finished and ready for precision bearings and lifters.

- This engine block is pre-threaded to accept GM LT1/LT4 Style piston oil nozzles (GM PN 12678499)

- Confirm all installed components have sufficient clearance in relation to block casting features. This includes all rotating assemblies and the valvetrain components.

- The engine block requires thorough cleaning and inspection prior to assembly and run-in. Verify all oil passages are free and clear of machining debris prior to first startup.

TECHNICAL SPECIFICATIONS FOR LTR WET DECK ENGINE BLOCKS:

Specification	Measurement & Tolerance (inches)
Deck Height	9.251"
Cylinder Bore	4.110"
Maximum Cylinder Bore Size	4.185"
Cam Bore	2.3075" - 2.3088"
Lifter Bore	0.8430" - 0.8435"
Main Bore	2.7475" - 2.7485"

MAIN STUD TORQUE SPECIFICATIONS FOR LTR WET DECK ENGINE BLOCKS:

- Inner main stud nuts – 60 ft-lb
- Outer main stud nuts – 50 ft-lb
- Cross-bolts – 50 ft-lb

TORQUE SEQUENCE FOR MAIN STUDS AND CROSS-BOLTS

