

## INSTALLATION INSTRUCTIONS

**SUBJECT: LML CP3 CONVERSION KITS FOR 2011-2016 DURAMAX  
(KITS WITH A BUILD DATE AFTER 1/22/2024)**

FPE-2021-56  
Revised January 2024  
Page 1 of 23

**FITMENT:** 2011–2016 GMC Sierra and Chevrolet Silverado 2500/3500  
**P/N's:** FPE-LML-CP3-WP, FPE-LML-CP3-NP, FPE-LML-CP3-10

**EST. INST. TIME:** 12 - 14 Hours

**TOOLS REQUIRED:** ½" fuel disconnect, 3/8" fuel disconnect, 3/8" ratchet, metric socket set, metric wrench set, 1 1/16" socket, 27mm socket, 3/8" socket extensions, fan clutch removal tool, 3/8" and ½" torque wrench, ¼" and 5/16" nut driver, pliers, 9/16" wrench, 7/8" wrench, 15/16" wrench, pry bar, hose pick.

### ADDITIONALLY RECOMMENDED PARTS:

GM Pressure Regulator P/N: 12611872  
GM Injector Return Lines and Regulator P/N: 12639000  
GM Fuel Feed Pipe P/N: 12654066  
GM Fuel Temperature Sensor P/N: 12643002  
GM Return Hose Banjo Seal P/N: 12630832  
GM Dosing Injector Feed Line P/N: 12656313

### WARNINGS / IMPORTANT NOTES:

- THIS KIT MAY INCLUDE UPDATED COMPONENTS FROM PREVIOUS INSTALLATIONS YOU HAVE PERFORMED. FOLLOW ALL INSTRUCTIONS OUTLINED IN THIS DOCUMENT. IF YOU HAVE QUESTIONS ON THE INSTALLATION, EMAIL US AT [INFO@FLEECEPERFORMANCE.COM](mailto:INFO@FLEECEPERFORMANCE.COM) OR CALL US AT 317-286-3573.
- Thoroughly clean all fuel lines and components prior to installation with a solvent solution.
- **FPE-LML-CP3-WP:** For optimal performance of, if the truck is equipped with a lift pump, the feed pressure to the CP3 should not exceed 11 psi. Engine surging may be experienced at lift pump pressures over 11 psi.
- **FPE-LML-CP3-10:** This kit has been tested for use in stock application trucks that did not utilize a fuel lift pump. For optimal performance, if the truck is equipped with a lift pump, the feed pressure to the CP3 should not exceed 2 psi. Engine surging may be induced by the additional fuel pressure of a lift pump operating at pressures over 2 psi. If you are intending to combine this kit with a Fleece PowerFlo® lift pump, contact us for a lower rate spring for your pump to accommodate operation with this kit. For higher lift pump pressures, FCA table values will require adjustment.
- The purchaser and end user releases, indemnifies, discharges, and holds harmless Fleece Performance Engineering, Inc. from any and all claims, damages, causes of action, injuries, or expenses resulting from or relating to the use or installation of this product that is in violation of the terms and conditions on this page, the product disclaimer, and/or the product installation instructions. Fleece Performance Engineering, Inc. will not be liable for any direct, indirect, consequential, exemplary, punitive, statutory, or incidental damages or fines caused by the use or installation of this product.

# INSTALLATION INSTRUCTIONS

## ITEM LIST

ITEM	DESCRIPTION	QTY
1	<a href="#">CP3 to engine block adapter</a>	1
2	<a href="#">Fuel feed hose</a>	1
3	<a href="#">Fuel return hose</a>	1
4	<a href="#">High-pressure fuel line</a>	1
5	Low pressure fuel feed line	2
6	CP3 feed fitting & sealing washer	1
7	CP3 return fitting & sealing washer	1
8	Hose clamps	5
9	Fuel rail nut	1
10	O-ring (block adapter and pump snout)	2
11	M8x1.25x35mm bolts	3
12	<a href="#">Regulator extension harness</a>	1
13	Low pressure fuel line (S-line is an optional line for use only in trucks with an aftermarket lift pump)	1
14	Cascade return fuel line	1
15	Cascade feed fuel line	1
16	CP3 cascade banjo bolt	1
17	Cascade block	1
18	9/16" O-ring plug	1
19	14 mm copper washer	3
20	10 mm copper washer	2
21	10 mm x 1.0 banjo bolt	1
22	Fuel rail plug	1
23	<a href="#">CP3 Injection Pump</a> – Only included in <a href="#">FPE-LML-CP3-WP</a> and <a href="#">FPE-LML-CP3-10</a> (-10 shown)	1
24	CARB EO sticker (not shown)	1

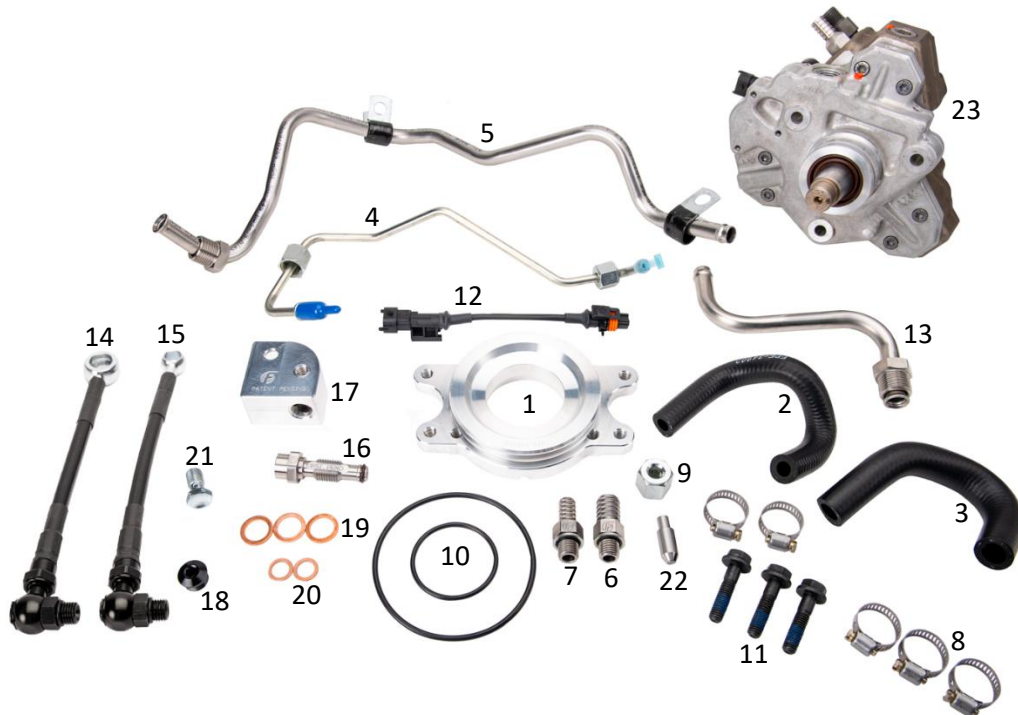

# INSTALLATION INSTRUCTIONS

## GENERAL OVERVIEW

Removal of the stock fuel injection pump involves the following key steps:

1. Disconnect both batteries, drain coolant system and remove air cleaner.
2. Remove intake air box and coolant surge tank bracket.
3. Disconnect black plastic cold side charge air cooler tube from throttle body and blue hot side charge air cooler pipe from turbocharger.
4. Disconnect chassis fuel lines from quick connect fittings at rear of engine.
5. Release accessory drive belt tensioner and remove turbocharger air resonator.
6. Unbolt and move aside A/C compressor and alternator(s).
7. Unbolt cooling fan from front of engine, move aside.
8. Remove intake manifold tube.
9. Remove EGR bypass pipe, valve, and front cooler.
10. Remove center intake manifold (Y bridge) and turbo air inlet adapter.
11. Remove turbocharger coolant return banjo pipe.
12. Remove high and low-pressure fuel lines. Disconnect the dosing injector feed line.
13. Remove stock injection pump. Remove fuel temperature sensor from the pump.
14. Swap gear and nut from the old CP4 injection pump to the new CP3 injection pump.

Installation of the new CP3 pump is as follows:

1. Install new injection pump (does not need to be timed).
2. Remove the cascade overflow valve from the CP3.
3. Install the CP3 cascade overflow valve and fuel temperature sensor into the supplied cascade block.
4. Install the new supplied cascade banjo bolt, cascade block, and two fuel feed lines.
5. Install secondary high-pressure rail plug.
6. Remove old high-pressure pump line anchor bracket from rail-to-rail high-pressure line.
7. Replace low pressure fuel supply tube with new tube and install to engine.
8. Install new supplied low pressure fuel supply hose and high-pressure fuel lines. Install new low-pressure feed and return hoses.
9. Install dosing injector feed line to the cascade block.
10. Install center intake manifold, EGR cooler, turbocharger air inlet adapter.
11. Install EGR bypass pipe, valve and intake manifold tube.
12. Reinstall turbocharger coolant banjo pipe w/ new seal.
13. Reinstall cooling fan assembly, alternator(s) and A/C compressor.
14. Install drive belt and turbocharger air resonator.
15. Reconnect cold side charge air cooler duct and hot side charge air cooler pipe.
16. Reconnect air cleaner, chassis fuel line connections, batteries.
17. Refill coolant.
18. Prime fuel system.
19. Initiate DPF Regeneration with scan tool to purge air from the hydrocarbon injector and the lines.

# INSTALLATION INSTRUCTIONS

## REMOVAL OF THE CP4 INJECTION PUMP

1. Disconnect both batteries, drain coolant system and remove air cleaner.
  - a. Do not use impact tools on the battery terminals.
  - b. Coolant is best drained from the lower radiator hose. Place a large bucket underneath the vehicle to drain the coolant into.
  - c. Air cleaner can be removed by first loosening the hose clamps and then gently pulling off the duct. The box itself can be removed by lifting upward. Be careful not to damage the A/C line during removal.
2. Remove airbox and coolant surge tank bracket. Next, disconnect black plastic cold side charge air cooler (CAC) tube from throttle body.
  - a. With a screwdriver, push the lock ring counterclockwise. As the locking ring is rotated, the CAC pipe itself can be gently pulled out and off.
  - b. Remove CAC pipe from the turbocharger.
3. Disconnect chassis fuel lines from quick connect fittings at rear of engine using a quick connect removal collar tool. Use 3/8" and 1/2" fuel disconnect tools to perform this.
4. Remove the four (4) cooling fan shroud bolts.
  - a. For 2015 vehicles, it is not necessary to remove the fan shroud, gently adjust the shroud towards the radiator to provide access to the cooling fan center.
  - b. For 2014 and earlier vehicles, the fan shroud is two piece and can be more easily removed.
  - c. Unbolt cooling fan mount from front of engine by loosening three 15mm bolts and two stud nuts.
  - d. Remove the fan from the drive pulley using a fan removal tool. Perform this before removing the belt.
5. Release tension of the accessory drive belt by rotating tensioner using a 1/2" drive socket wrench. The intake manifold cover (embossed with 6.6L Turbo Diesel) can be removed by loosening the two 10mm bolts affixing it to the intake pipe. Remove the alternator bracket.
6. Unbolt and move aside A/C compressor. The refrigerant does not need to be evacuated. The alternator(s) can be removed and put aside.

# INSTALLATION INSTRUCTIONS

Remove intake manifold tube. First loosen the two 13mm bolts affixing the pipe to the intake manifold near the MAP sensor. (see Fig. 1)

Next, loosen the oil dipstick tube bracket bolts and the hidden 10mm bolt affixing the intake air heater ground bracket to the intake pipe. (see Fig. 1)

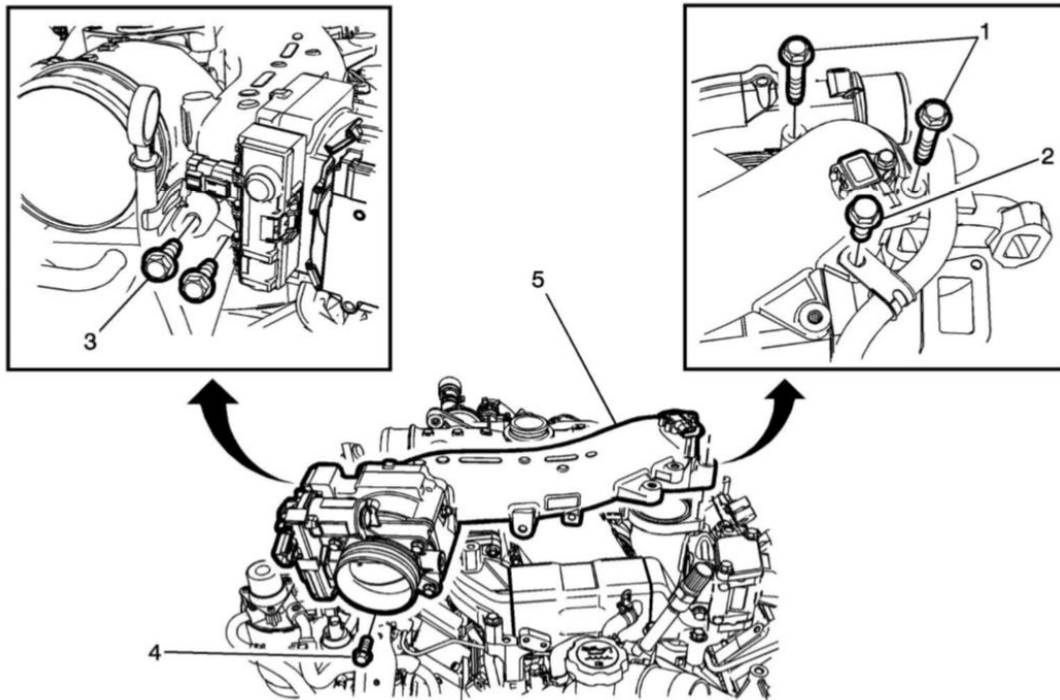

Fig. 1: Intake manifold tube

# INSTALLATION INSTRUCTIONS

7. Remove the turbocharger air inlet adapter.

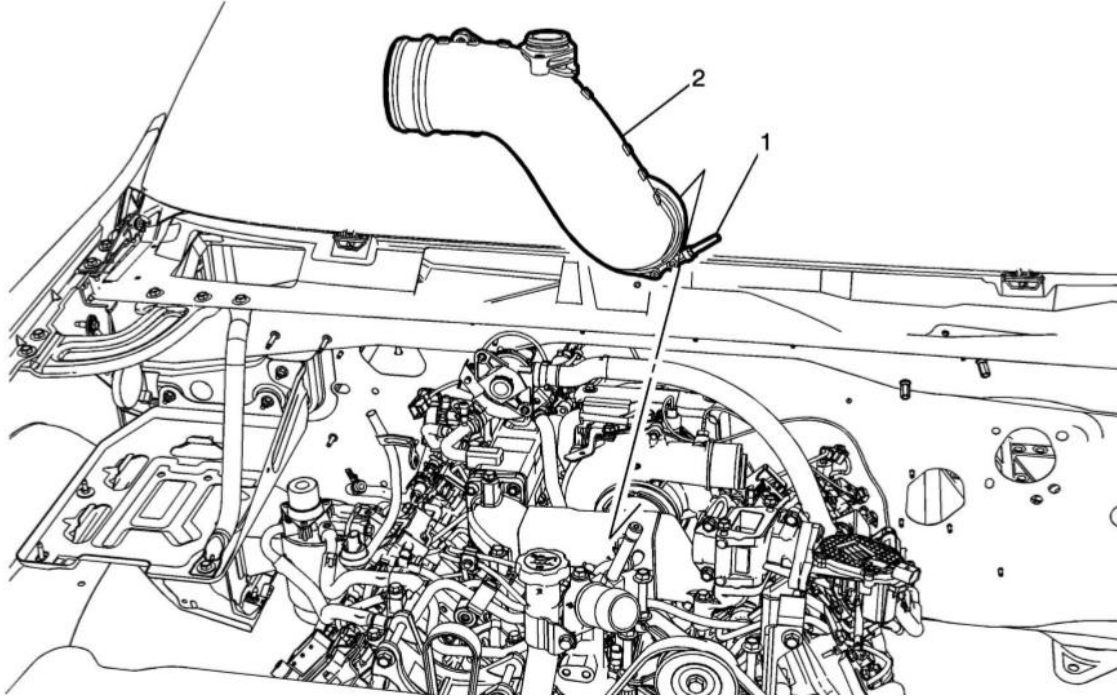

Fig. 2: Air inlet adapter removal

# INSTALLATION INSTRUCTIONS

8. Remove EGR bypass pipe, valve, and front cooler.
  - a. Remove the EGR bypass pipe that connects the EGR bypass valve to the EGR valve.

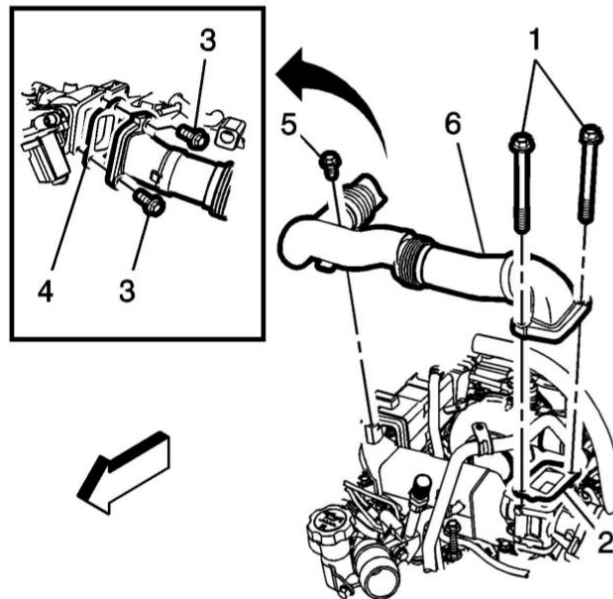

Fig. 3: EGR bypass pipe

- b. The EGR valve can then be removed by loosening the four bolts that attach it to the intake manifold.

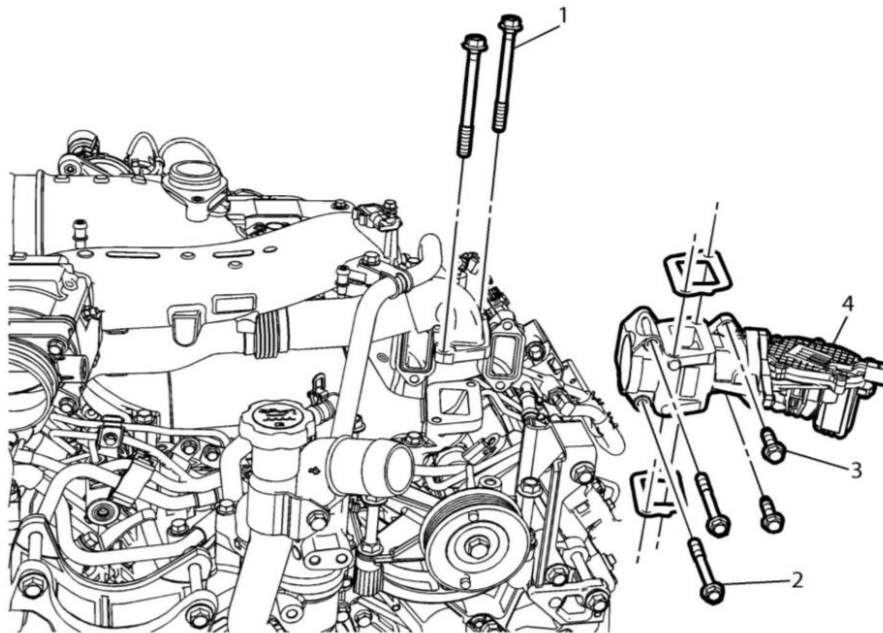

Fig. 4: EGR valve removal

# INSTALLATION INSTRUCTIONS

- c. The 4 front EGR cooler bolts can be accessed by carefully threading through a ¼" drive socket extension and a swivel socket.

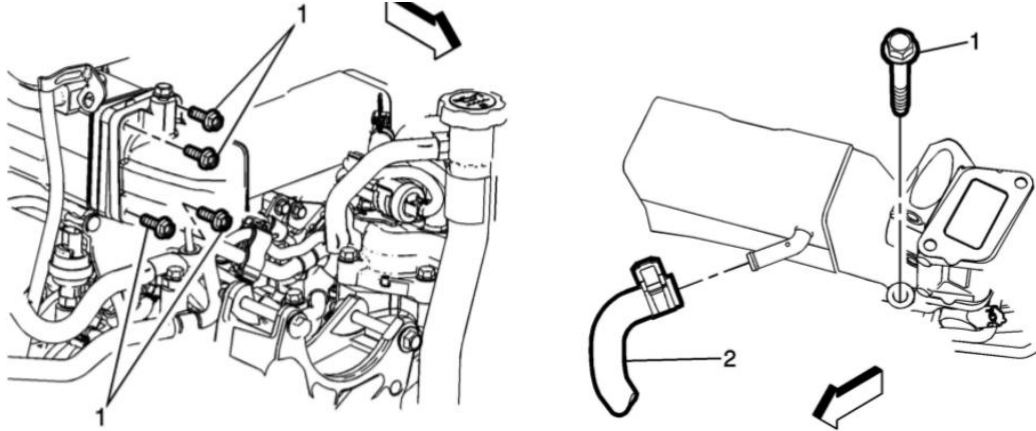

Fig. 5: EGR cooler removal

- 9. Remove the turbocharger air inlet adapter.

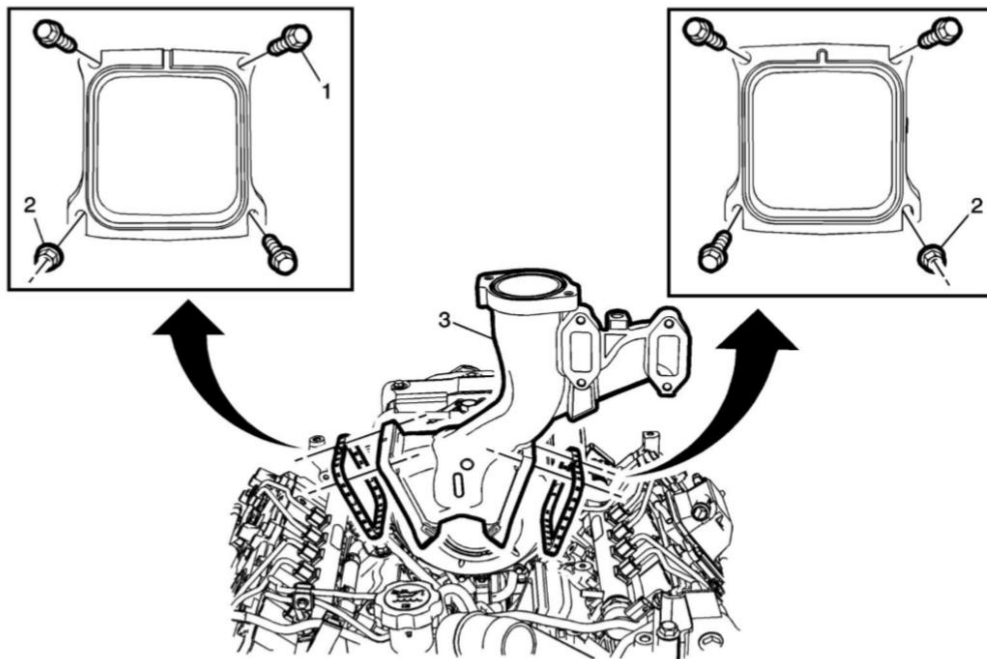

Fig. 6: Turbocharger air inlet removal

# INSTALLATION INSTRUCTIONS

10. Remove turbocharger coolant return banjo pipe from the turbocharger (Item #5 in Fig. 7 below)

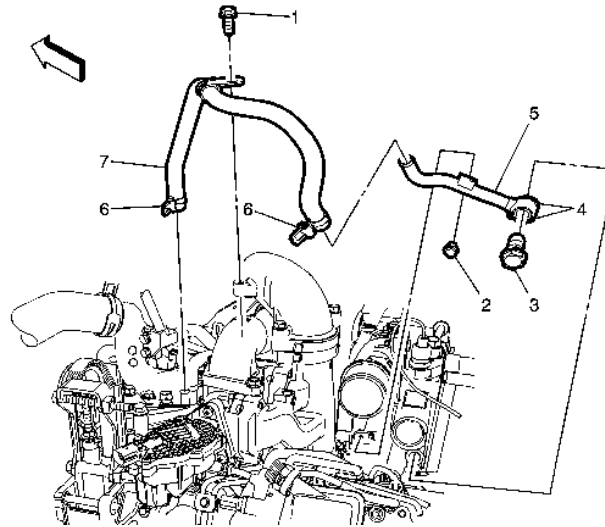

Fig. 7: Turbocharger coolant return pipe removal

11. Remove high- and low-pressure fuel lines.

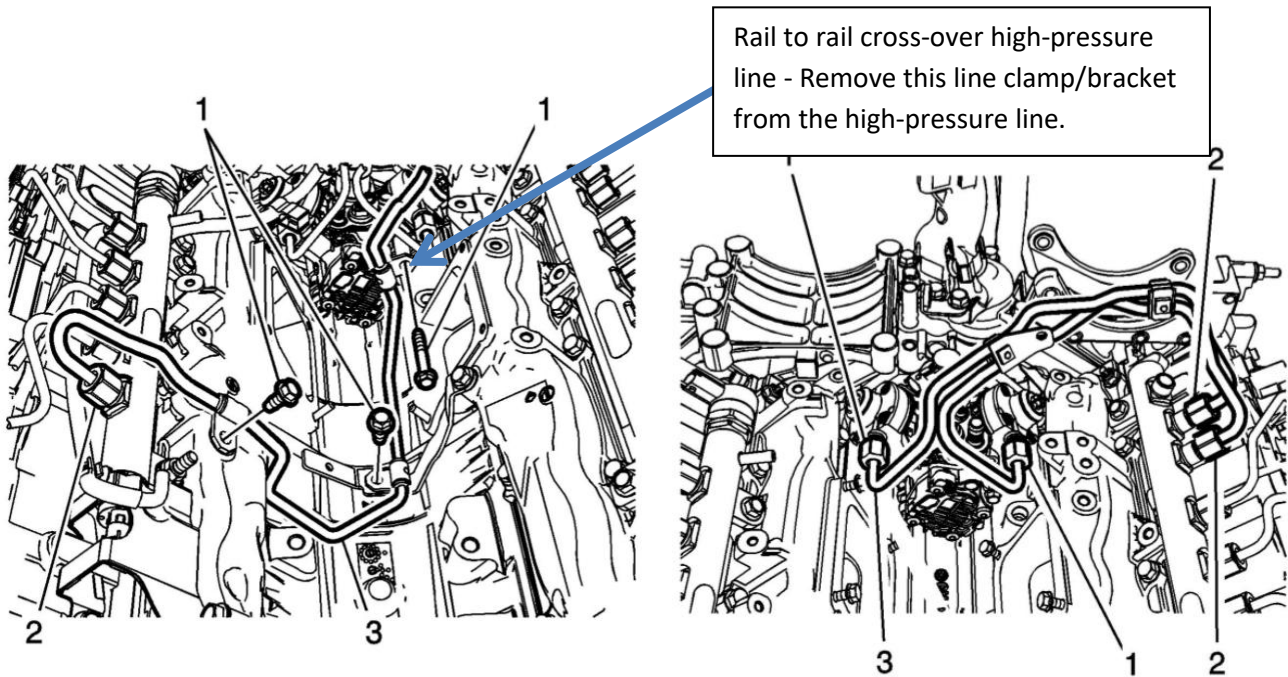

Fig. 8: High and low fuel pressure line removal

# INSTALLATION INSTRUCTIONS

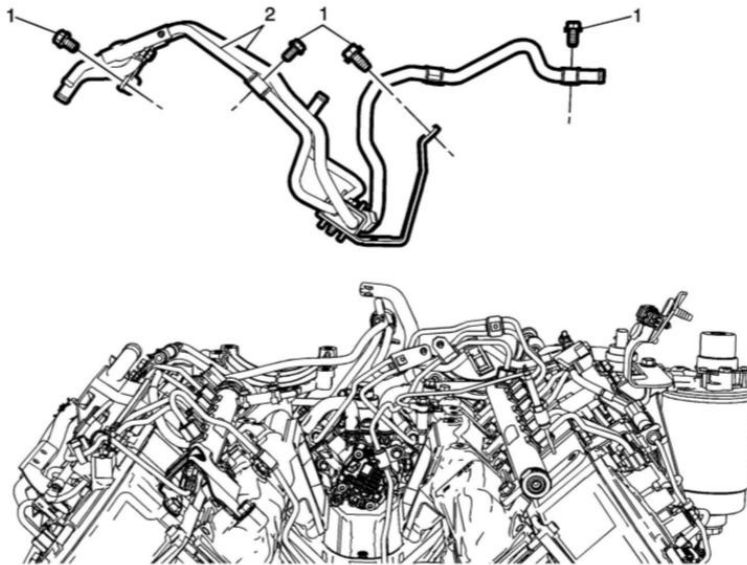

Fig. 9: Remove the rail-to-rail and CP4 lines

12. Disconnect electrical harness connectors for the fuel injection pump temperature sensor and pressure regulator.
13. Remove the four bolts that secure the CP4 injection pump to the cylinder block.

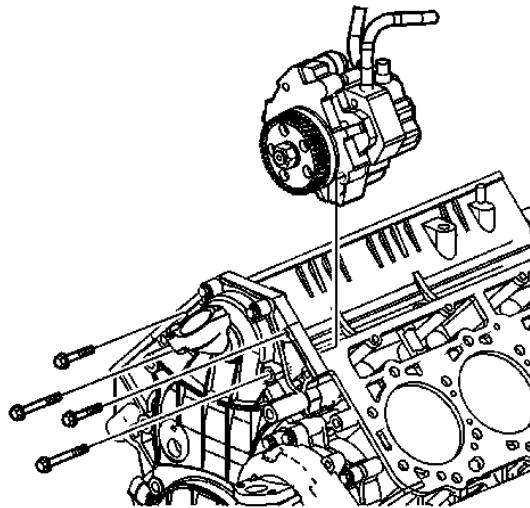

Fig. 10: Remove the CP4 pump

14. Remove CP4 injection pump.

# INSTALLATION INSTRUCTIONS

## PREPARE CP3 INJECTION PUMP FOR INSTALLATION

1. Remove the green fuel temperature sensor from the OLD injection pump. It will be reinstalled into the new cascade block.
2. Hold the OLD injection pump by the drive gear in a vice with soft jaws.
3. Remove nut and gear from shaft.
4. Clean all mating surfaces.
5. Install the CP3 to engine block adapter to the new injection pump with the 3 bolts supplied in the kit. Be sure to lubricate the flange O-ring with engine oil prior to installation or an oil leak could occur. Torque the bolts to 20 ft-lb.
6. Install the gear and torque the gear nut to 75 ft-lb. DO NOT OVERTORQUE.
7. Remove the original Bosch CP3 feed and return fittings from the pump and install the new high flow CP3 feed and return fittings onto the CP3 pump. See Fig. 11.

**IMPORTANT NOTE:** The CP4 nut is longer than the CP3 nut, however, it will not interfere with the front cover. It will also provide the same amount of thread engagement. The shaft of the CP3 will be below the nut surface – THIS IS OK, SEE Fig. 12

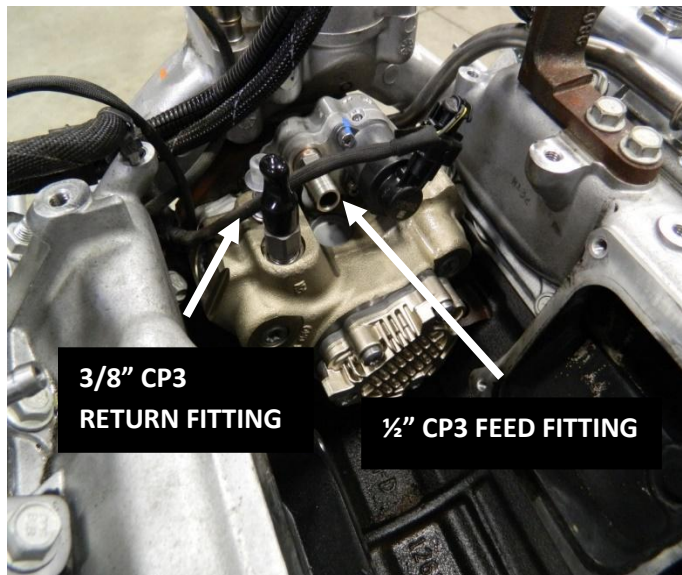

Fig. 11: Install the CP3 feed and return fittings



Fig. 12: Install the CP4 nut onto the CP3

# INSTALLATION INSTRUCTIONS

## INSTALLATION OF NEW CP3 PUMP

**IMPORTANT NOTE:** We recommend removing and inspecting the high-pressure regulator and inspecting it for debris. If debris is found in the high-pressure regulator, we recommend replacing the regulator, the injector return line and check valve assembly.

GM Pressure Regulator P/N: 12611872

GM Injector Return Lines and Regulator P/N: 12639000

Lubricate the O-rings on the new injection pump adapter with engine oil and install onto the cylinder block. Note the CP3 pump does not need to be timed to the camshaft. Torque the four bolts to 18 ft-lb. Do not draw the pump into the block using the attachment bolts or they may strip out of the aluminum mounting plate, it must be pushed into position.

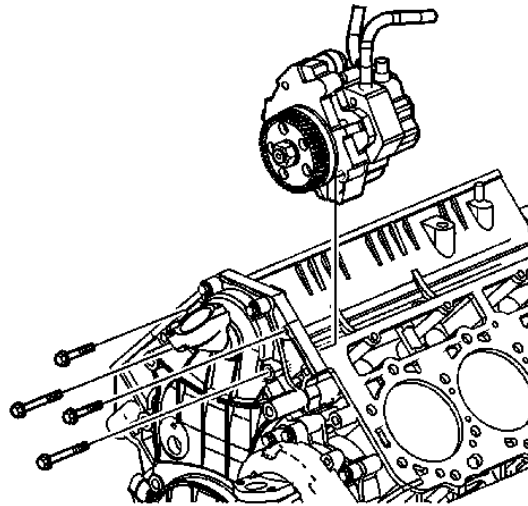
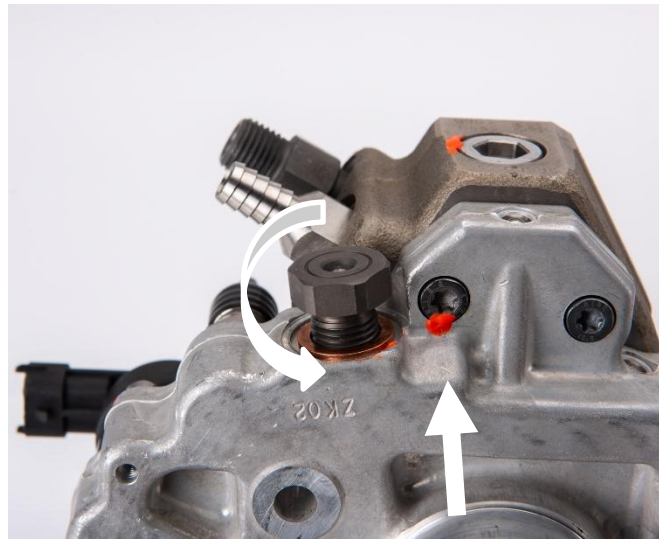

Fig. 13: Install the CP3

# INSTALLATION INSTRUCTIONS

## ROUTE AND INSTALL THE CASCADE BLOCK AND DOSING INJECTOR FUEL LINE

1. Thoroughly clean the area around the cascade overflow valve on the top of the CP3 pump using brake clean or other solvent to remove all dirt or debris. Remove the cascade overflow valve from the CP3 injection pump using a 19mm socket or wrench. Ensure no debris enters the pump during removal of the valve. Carefully clean the surrounding area after removal of the valve.



2. Using clean fuel, lubricate the O-ring on the cascade overflow valve removed from the CP3 pump. Install the cascade overflow valve along with a new 14mm copper washer into the supplied cascade block (item 17). Tighten the cascade overflow valve fitting to 20 ft-lbs.

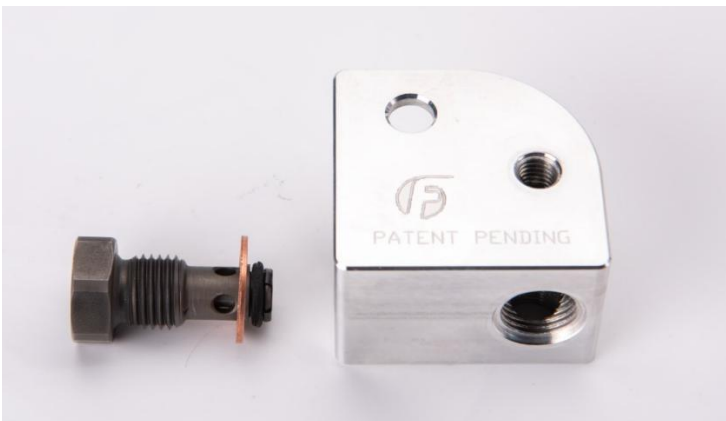

## INSTALLATION INSTRUCTIONS

3. Install the 9/16" O-ring plug (item 18) included with the kit into the cascade block. Tighten to 10 ft-lbs.



4. Install the fuel temperature sensor removed from the CP4 into the bottom of the cascade block. Torque to 20 ft-lbs.

*IMPORTANT NOTE: Inspect the sealing washer on the temperature sensor for any damage, defects, or excessive corrosion on the surface of sealing washer. The sealing washer is not individually serviceable, so the sensor assembly must be replaced if damage, defects, or corrosion are present. Fuel Temperature Sensor GM P/N 12643002.*



## INSTALLATION INSTRUCTIONS

- Lubricate** the o-rings on both cascade fuel lines with clean fuel. Install the cascade return fuel line (item 14) to the port on the underside of the block nearest to the top of the cascade overflow valve. The o-ring swivel fitting will be attached to the cascade block. Tighten using a 9/16" wrench and torque to 120 in-lbs. Install the cascade feed fuel line (item 15) onto the cascade block into the remaining port nearest to the fuel temp sensor. Use a 9/16" wrench and torque to 120 in-lbs.



- Lubricate** the O-ring on the cascade banjo bolt (item 16) with clean fuel prior to assembly. Route the large banjo fitting over the top of the injection pump and install the new CP3 cascade banjo bolt and two 14mm copper washers supplied in the kit into the bore on the CP3 pump. Route the cascade return fuel line so that it is parallel to the front face of the CP3 pump. Tighten the fitting to 20 ft-lbs. (Image below shown off vehicle for clarification only)



## INSTALLATION INSTRUCTIONS

7. Route the cascade feed line with the small banjo fitting to the top of the new CP3 cascade bolt. Connect the feed line to the top of the new cascade bolt using the supplied banjo bolt (item 21) and two 10mm copper crush washers (item 20). Snug the banjo bolt, but do not tighten it. The fitting will be tightened once the cascade block is bolted in place.

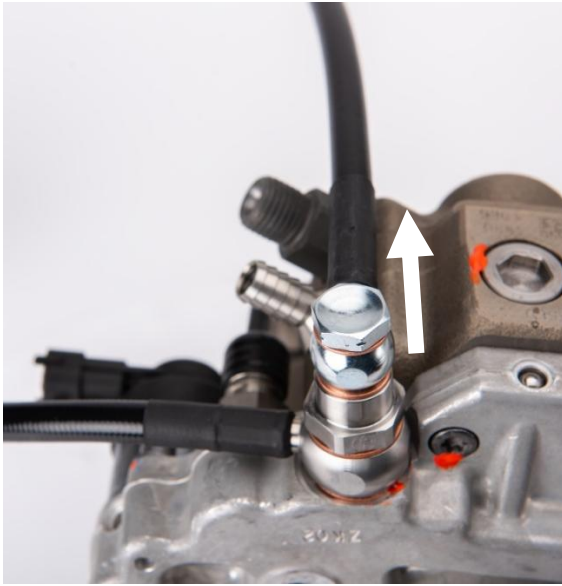

8. Retain the cascade block to the engine by securing it with the M8 bolt that originally retained the dosing injector feed line from the CP4. Torque to 10 ft-lbs. With the cascade block now in place, torque the snugged banjo bolt on the CP3 to 120 in-lbs.

## INSTALLATION INSTRUCTIONS

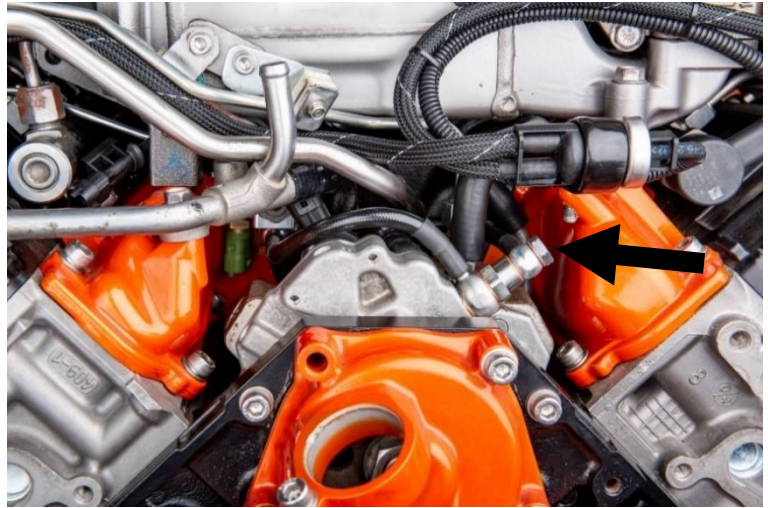
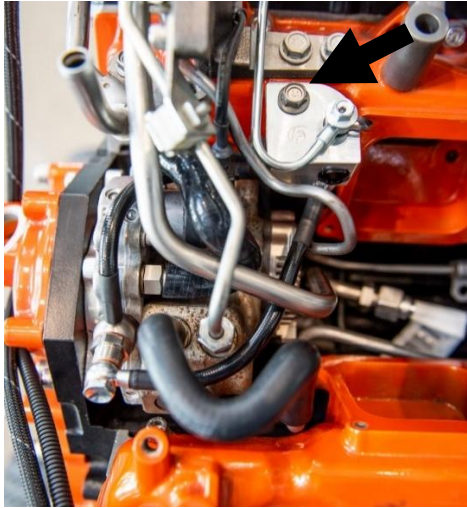

With the cascade block now in place, install the banjo bolt for the dosing injector supply line to the cascade block. Torque to 89 in-lbs. (Image below shown off vehicle for clarification only) Use of a new GM banjo seal is recommended if not installing a new dosing injector feed line.

GM RETURN HOSE BANJO SEAL PART NO: 12630832

GM DOSING INJECTOR FEED LINE PART NO: 12656313

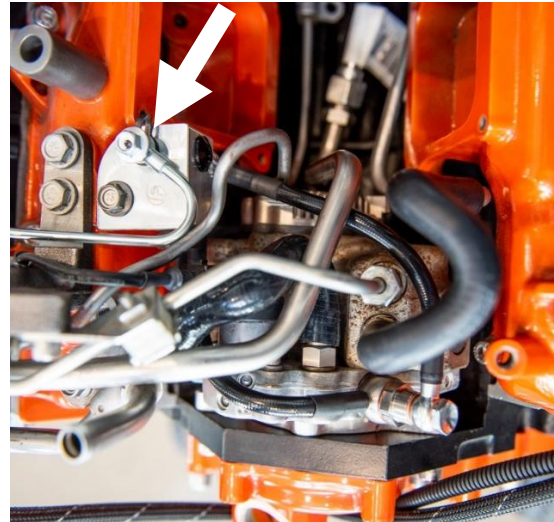
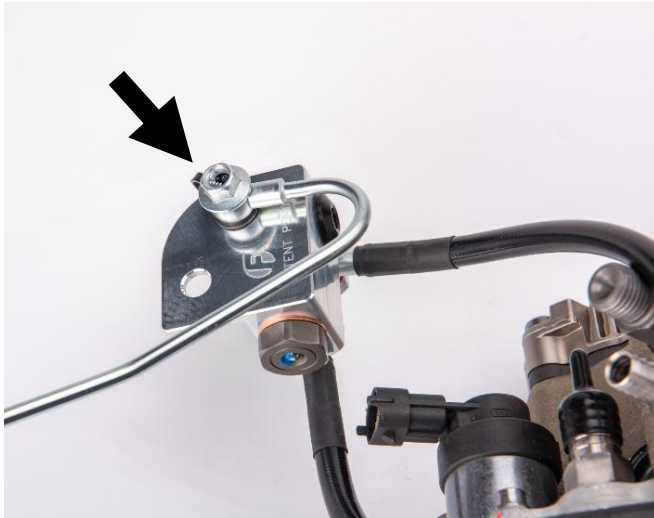

# INSTALLATION INSTRUCTIONS

## INSTALLED CP3 FUEL LINE ROUTINGS

Low Pressure Fuel Feed Line: Item 5 in kit

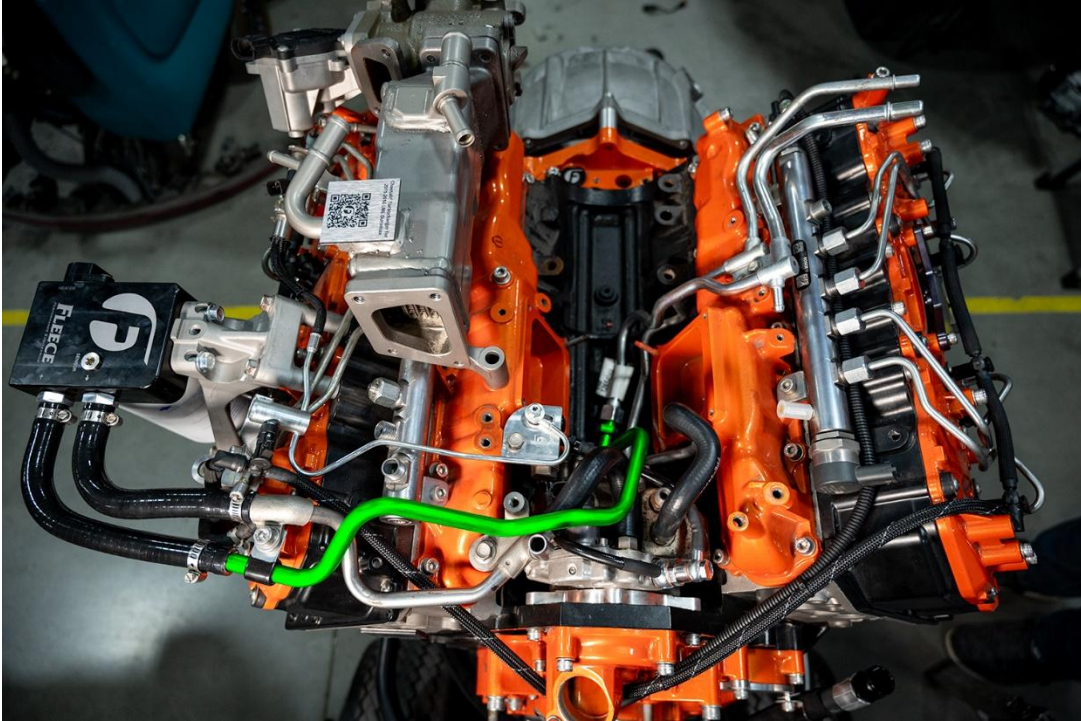

Fuel Feed Hose: Item 2 in kit

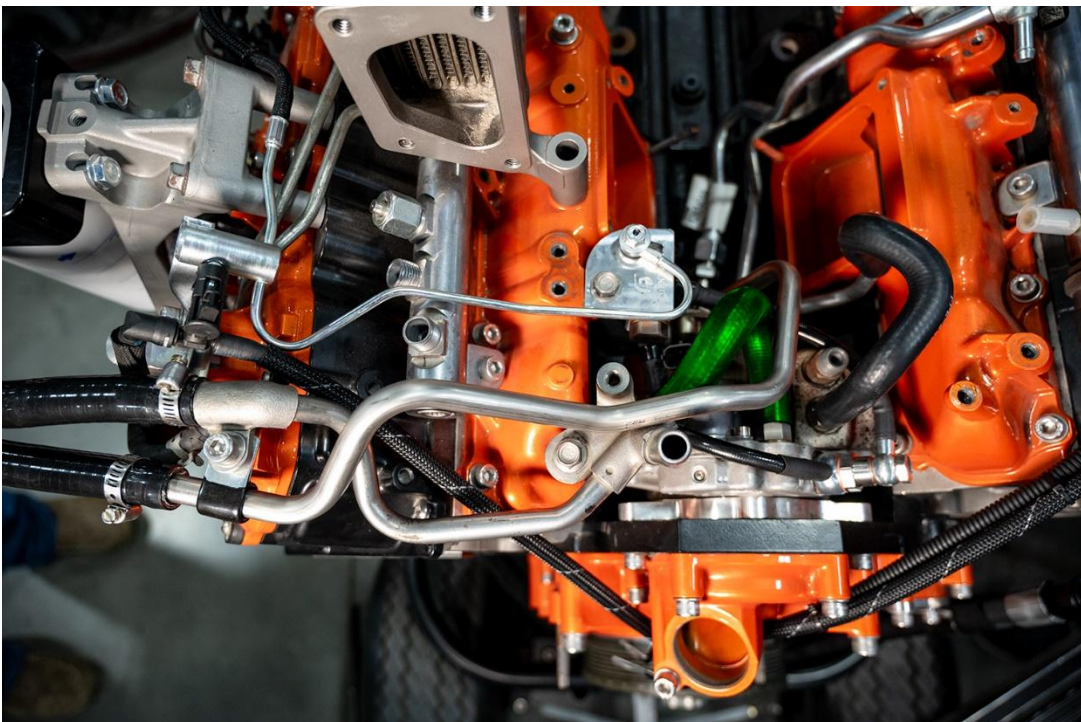

# INSTALLATION INSTRUCTIONS

Fuel Return Hose: Item 3 in kit

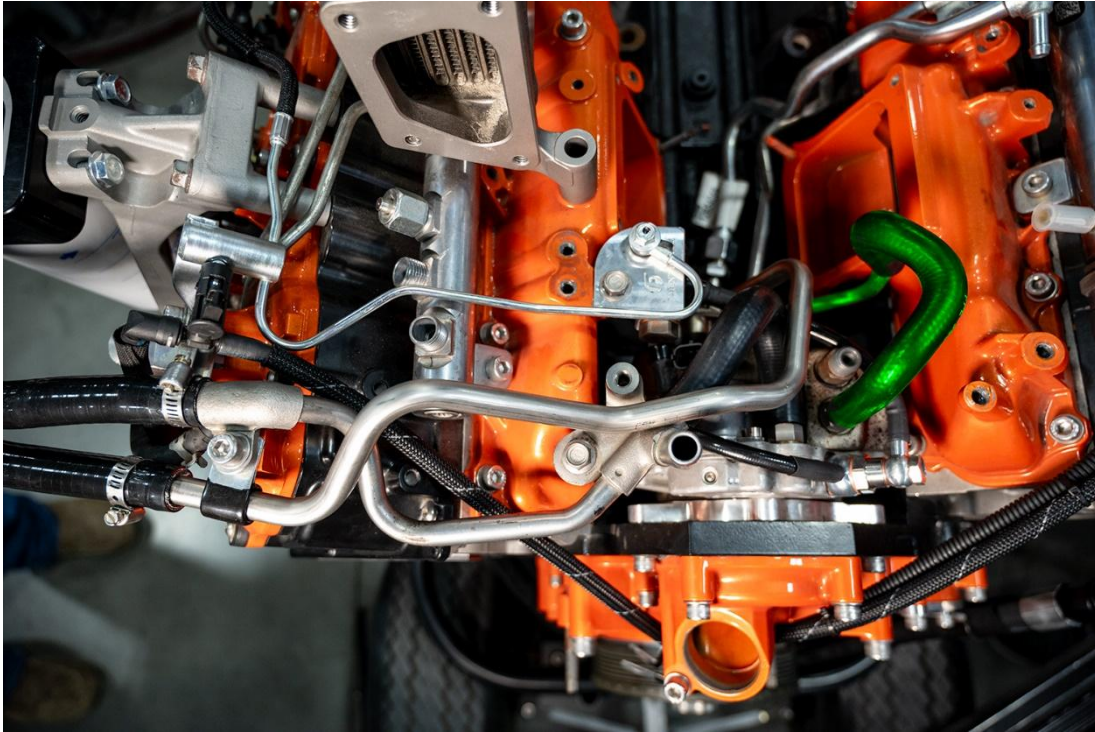

High Pressure Fuel Line: Item 4 in kit

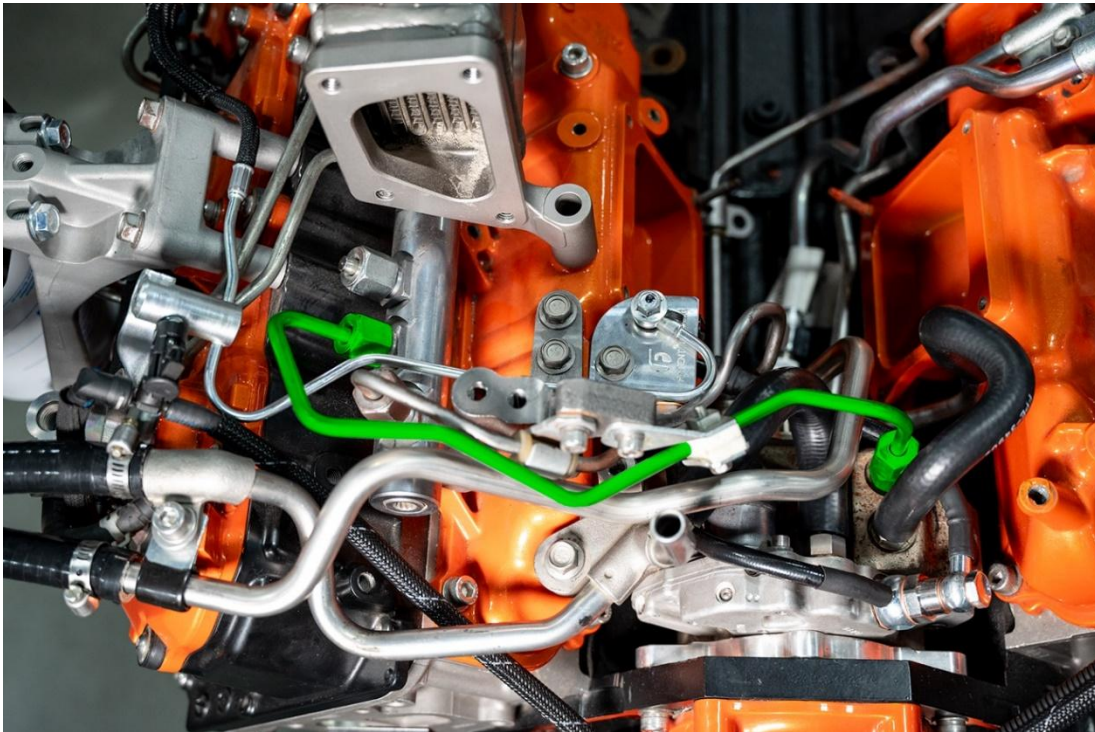

# INSTALLATION INSTRUCTIONS

Cascade Return and Feed Lines: Items 14 and 15 in kit

OE Dosing Injector Feed Line reused

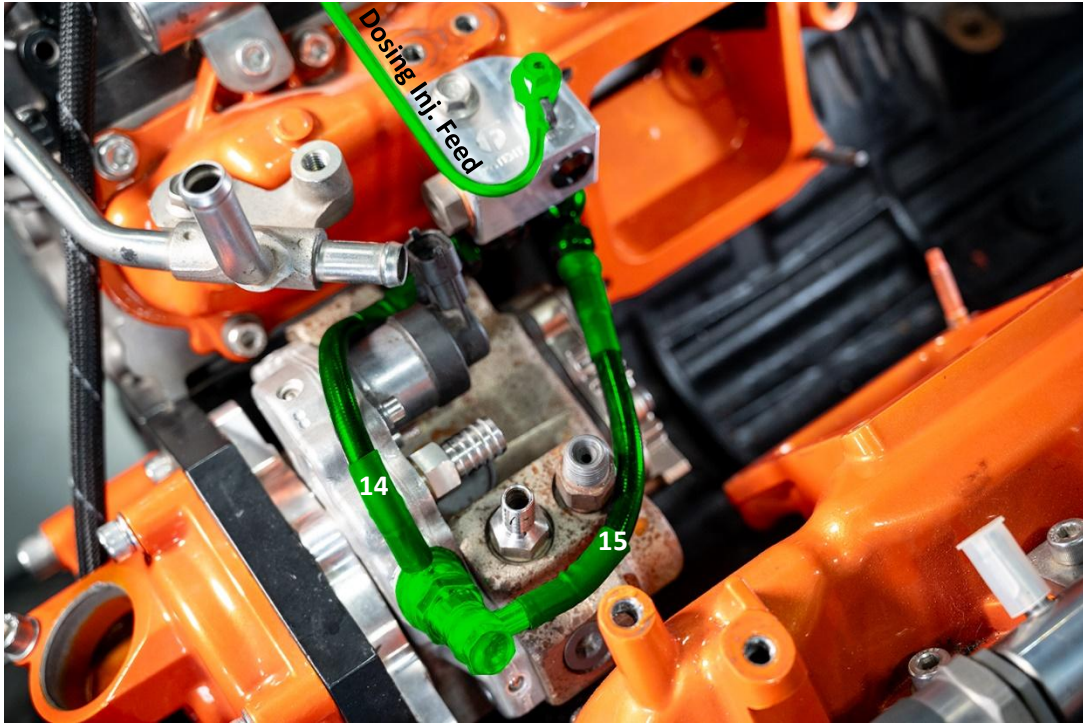

## INSTALLATION INSTRUCTIONS

Before re-installing the rail-to-rail cross-over high-pressure fuel line, remove the high-pressure line clamp/bracket. This is most easily performed with the bracket held in a vice and separated with a small pry or heel bar. Do not nick or damage the high-pressure line in any way. Install cross-over high-pressure line and secondary high-pressure rail plug and torque fittings to 30 Nm (22 ft-lb). The high-pressure rail plug provided goes towards the open feed port toward rear of vehicle while the NEW supplied high-pressure feed line from the CP3 goes toward the front.

**IMPORTANT NOTE:** Torque is critical. Under or over torque will result in fuel leaks.

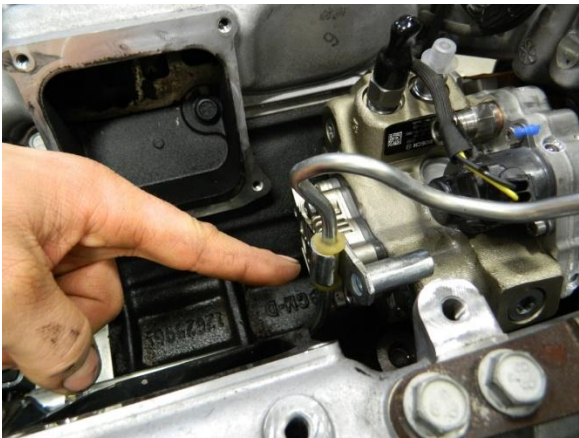

Carefully remove high pressure line bracket

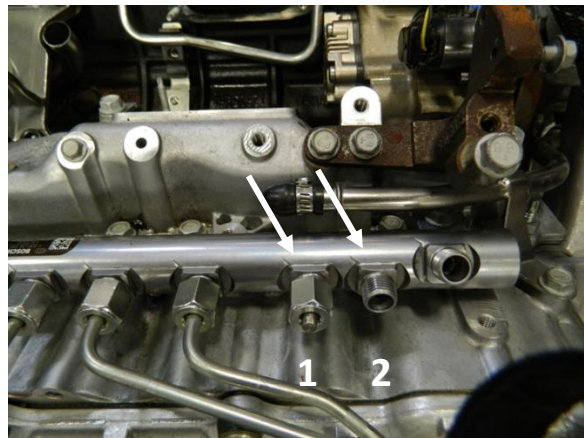

Fuel rail nut (1) and high-pressure line (2)

Replace low pressure fuel supply line with new extension and install to engine. Torque the compression fitting to 35 Nm (26 ft-lb).

**IMPORTANT NOTE:** Clean and lightly lubricate low pressure feed tube compression fitting to ease installation in the valley. Fleece Performance recommends replacing the existing fuel feed pipe since leaks can occur due to deformation or corrosion on the compression fitting.

GM Fuel Feed Pipe P/N: 12654066

Attach supplied fuel hose to the OEM fuel pump supply pipe and secure with constant tension clamps. Install the new fuel return hose. Be sure the return hose does not make contact with the high-pressure fuel line.

Install new high-pressure line from pump outlet to RH rail. Torque pump connection fittings to 38 Nm (28 ft-lb) and rail connection fitting to 30 Nm (22 ft-lb).

# INSTALLATION INSTRUCTIONS

## ENGINE COMPONENT RE-ASSEMBLY, PRIMING, AND TEST

1. Reinstall turbo coolant banjo pipe. Torque to 35 Nm (26 ft-lb).
2. Install center manifold (Y-bridge). Torque bolts and nuts to 10 Nm (89 in-lb).
3. Install turbocharger air inlet adapter. Torque clamp to 10 Nm (89 in-lb).
4. Install EGR cooler. TIP: hand-start all EGR fasteners prior to tightening. Torque bolts to 25 Nm (18 ft-lb).
5. Install EGR bypass pipe and EGR valve. Torque all EGR bolts to 25 Nm (18 ft-lb).
6. Install intake manifold tube to engine. Torque all fasteners to 25 Nm (18 ft-lb).
7. Reinstall alternator(s) Torque generator bolts to 58 Nm (43 ft-lb). Battery cable nut should be torqued to 12 Nm (106 in-lb).
8. Reinstall A/C compressor. Torque bolts to 58 Nm (43 ft-lb).
9. Install drive belt and center intake manifold cover.
10. Reinstall cooling fan / pulley assembly. Torque to 41 Nm (30 ft-lb).
11. Reinstall fan shroud assembly. Torque fan shroud bolts to 8 Nm (71 in-lb).
12. Reconnect cold side charge air cooler duct and hot side charge air cooler pipe.
13. Reconnect air cleaner.
14. Reconnect chassis fuel line connections.
15. Reconnect battery cables. Torque to 5 Nm (44 in-lb).
16. Refill coolant using vacuum fill system or GM static fill procedure. Be sure to fill slowly so that overflow side of tank is at least ½ full.
17. Replace fuel filter cartridge. NEW GM AC DELCO P/N 12664429 is recommended to ensure reliability of the fuel system.
18. Affix the CARB EO decal included with the kit in a clearly visible location in the engine bay.
19. Prime fuel system:
  - a. Pump the priming pump repeatedly until it becomes hard.
  - b. Loosen the bleeder screw until fuel flows freely with no air present.
  - c. Check the fuel system for leaks.
  - d. Crank the engine for 10 secs or until the engine fires.
  - e. If the engine does not start and no leaks are observed, pump the priming pump repeatedly until it becomes hard again. Crank engine again for 10 second intervals until the engine starts. It may take 3-4 priming events to get the engine started.
20. The hydrocarbon injector (HCI) and line must be purged. If the injector is not purged, the residual fuel and air at the injector can cause coking and may cause the injector to stick. To purge the air, initiate a DPF Regeneration Enable with a scan tool. During the forced regeneration the injector will be activate and air will be purged from the dosing injector feed line and dosing injector.

## Torque Specifications Reference Table

Part/Description	Torque Spec.	Page Number
CP3 to engine block adapter	20 ft-lb	11
CP3 gear nut	75 ft-lb	11
CP3 adapter to block	18 ft-lb	12
Cascade Valve to cascade block	20 ft-lb	13
O-ring plug to cascade block	10 ft-lb	14
Fuel temp sensor to cascade block	20 ft-lb	14
Cascade return to cascade block	120 in-lb	15
Cascade feed to cascade block	120 in-lb	15
Cascade banjo bolt to CP3	20 ft-lb	15
Cascade block mounting bolt	10 ft-lb	16
Cascade feed banjo bolt	120 in-lb	16
Dosing injector feed banjo bolt	89 in-lb	17
High pressure rail plug nut	22 ft-lb	21
Low pressure fuel supply line	26 ft-lb	21
High pressure feed to CP3	28 ft-lb	21
High pressure feed to rail	22 ft-lb	21
Turbo coolant banjo pipe	26 ft-lb	22
Center Manifold (Y bridge)	89 in-lb	22
Turbocharger air inlet adapter	89 in-lb	22
EGR Cooler	18 ft-lb	22
EGR Bypass Pipe and EGR Valve	18 ft-lb	22
Intake manifold tube	18 ft-lb	22
Alternator generator bolts	43 ft-lb	22
Alternator battery cable nut	106 in-lb	22
AC Compressor	43 ft-lb	22
Cooling fan/pulley assembly	30 ft-lb	22
Fan shroud assembly	71 in-lb	22
Battery cables	44 in-lb	22